



Single Media transport High-tech Design + latest functionality

Books, CD/DVDs, AV media, illustrated books and periodicals: whatever media items you want to transport, the recently developed UniSortCar™ is suitable for all items, with its functional square format and stable fixing on track. Media items travel along the sorting belt to the cars from any desired starting position. Individual items are transported safely thanks to an elastic inner coating. An electronic locking

system protects the contents of the car from being removed during transport.

THE single media transport solution for:

- Books
- Documents
- Magazines
- DVDs / CDs
- and many more

UniSortCar™ features:



- New Industrial Design
- Gentle media transport
- Dammed surfaces inside
- Fully integrated and automated single media transport
- Up to 0.6 m/s
- Safety bumper as contact protection
- On-board data processor
- Made of aluminum
- Electronic trolley-ID

**MADE
IN
GERMANY**

*More than 1300 installations worldwide!
More than 50 years experience!*

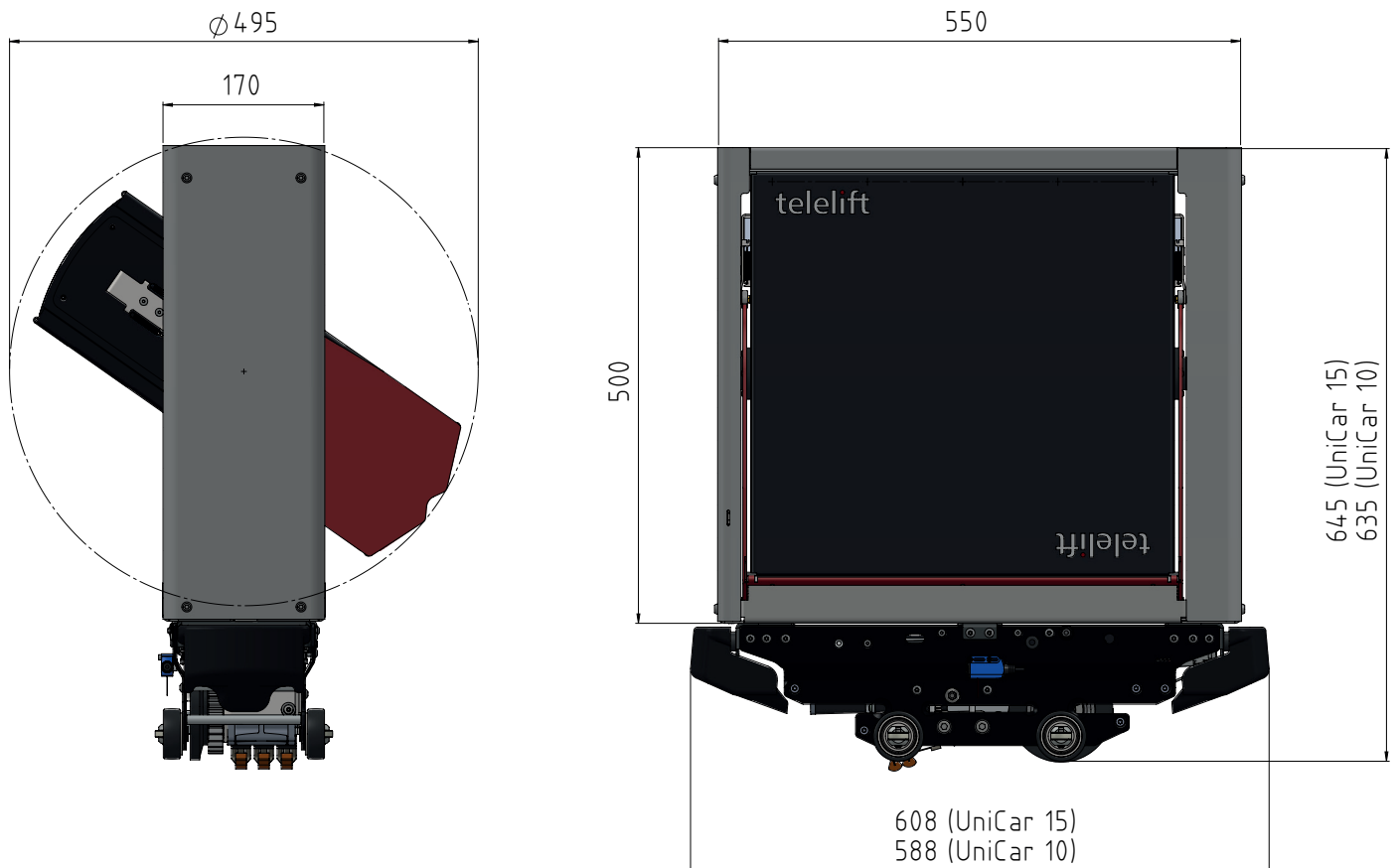

Even greater flexibility!

Loading and unloading is a controlled and reliable background process and can be automatic or manual from the left or the right side of the track. The UniSortCar™ can unload in both directions, offering more route variations. Once at the destination, up to twelve individual sub-destinations can be triggered. The UniSortCar™ takes just a few seconds at the sorting belt to take the book and send it on its way. Several cars are activated automatically at peak times. When returns are low the UniSortCars™ are parked in a special area ready to be called up.

Transport weight and dimensions:

- Min. transport weight: 30 g
- Max. transport weight: 3.500 g
- Min. dimensions: 100 mm x 100 mm x 5 mm
- Max. dimensions: 340 mm x 340 mm x 120 mm